

Specification MOSA/CV2201 Issue 3. Dated 20.9.54 To be read in conjunction with BS 1409 and K1001	<u>SECURITY</u>	
	<u>Specification</u> UNCLASSIFIED	<u>Valve</u> UNCLASSIFIED

—————> Indicates a change

TYPE OF VALVE - Disc Seal Triode Oscillator CATHODE - Indirectly Heated ENVELOPE - Glass PROTOTYPE - VX.3103			<u>MARKING</u> See K1001/4
<u>RATING</u>	Note	<u>DIMENSIONS AND CONNECTIONS</u> See drawing on Pages 3, 4 and 5.	
Heater Voltage (V) 6.3 A Heater Current (A) 2.0 Max. Pulse Anode Voltage (kV) 4.5 B,C Max. Anode Dissipation (W) 10 D Max. Mean Anode Current During Pulse (A) 4.0 Amplification Factor 28 E Mutual Conductance (mA/V) 12 E			
<u>Efficiency</u>			
At 1000 Mc/s	40%		
At 1200 Mc/s	35%		
At 1750 Mc/s	15%		
<u>CAPACITANCES (pF)</u>			
C in (nom)	4.3	F	
C out (nom)	1.5	F	
Ca, g1 (nom)	5.5	F	
<u>NOTES</u>			
A. For the above ratings the heater voltage should be kept at 6.3 V \pm 5%.			
B. Absolute maximum values.			
C. The valve has been designed for use under pulse conditions with Anode Modulation, the applied pulses not exceeding 3.0 μ sec. duration.			
D. The temperature of the disc at the anode seal must not exceed 100°C. To limit the rate of change of anode seal temperature the mass of metal in close thermal contact with the anode disc must be not less than 4 ozs., unless forced air cooling is used, when some decrease may be permitted.			
E. Measured at Va = 300 V; Ia = 50 mA.			
F. Measured at a frequency of 1.0 Mc/s.			

CV2201/3/1

To be performed in addition to those applicable in K.1001

Test Conditions					Test	Limits		No. Tested	Note	
						Min.	Max.			
a	Measurement to be made at a frequency of 1 Mc/s				CAPACITANCES (pF) C in C out Ca, g1	3.4 0.5 4.5	5.2 2.5 6.5	100% 100% 100%		
	Vh	Vg	Va	Ia mA						
b	6.3	0	0	0	Ih (A)	1.9	2.1	100%	1	
c	6.3	Adjust	300	50	Vg (V)	-4	-9	100%	1	
d	6.3	Adjust	300	50	Reverse Ig (μ A)	-	5	100%	1	
e	6.3	Adjust	250	50	Vg change from value obtained in (c)	(V)	1.4	2.1	100%	1
f	6.3	Adjust	300	50	gm (mA/V)	9	-	100%	1	
		Peak grid swing \pm 0.5 volt								
g	6.3	Adjust	300	2	Vg (V)	-	-30	100%	1	
h	6.3	Anode and grid strapped. Peak applied voltage 500V. Tp = 2 μ sec. Pulse shape sinusoidal PRF 50 o/s			Peak Emission (A)	15	-	100%	1	

NOTES

1. For these tests the precautions in note (D) on Page 1 shall be observed.

FIG 1.

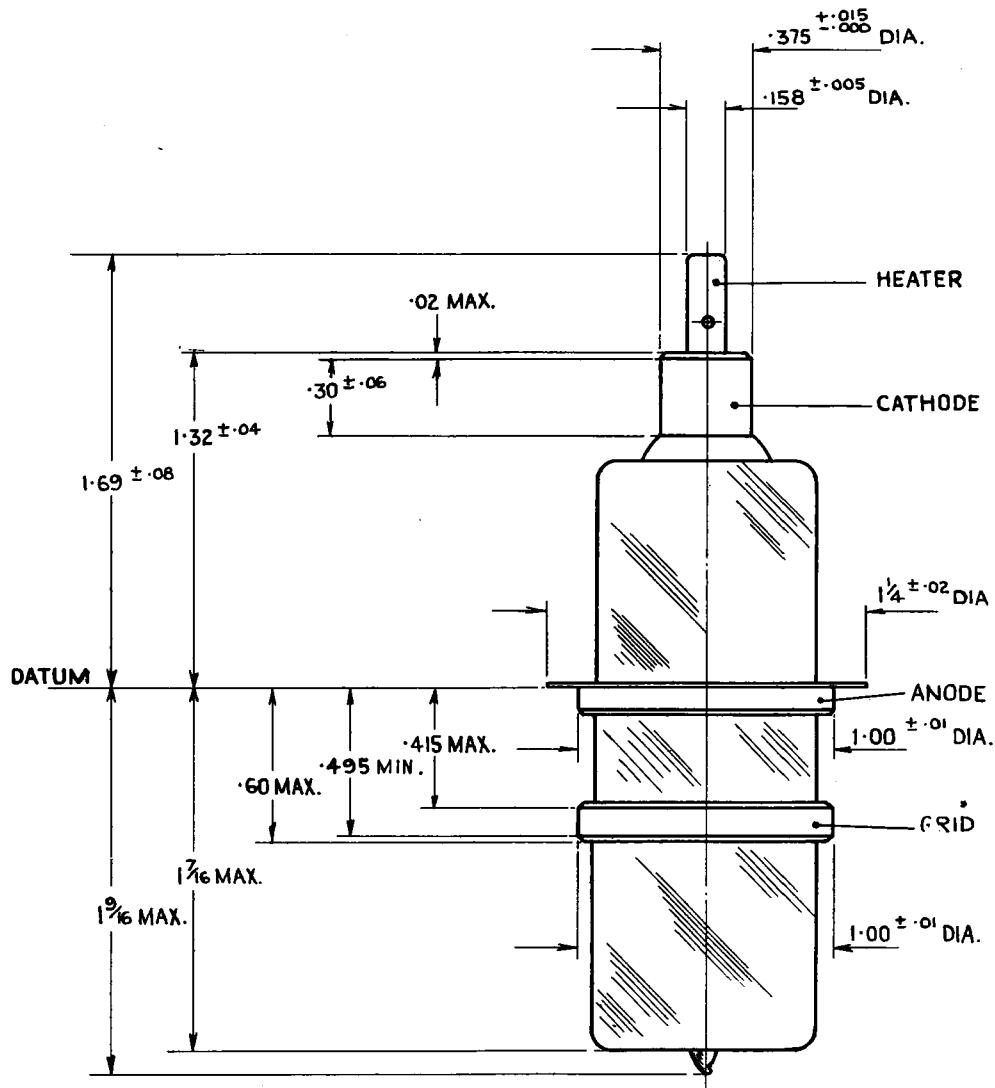
**NOTES**

ALL EXTERNAL CONTACT SURFACES TO BE RHODIUM PLATED.
 RIGID CONNECTION TO BE MADE TO ANODE ONLY.
 THE FINISHED VALVE WILL BE EXAMINED FOR ALIGNMENT OF ANODE, GRID,
 CATHODE, AND HEATER CONTACTS BY MEANS OF THE GAUGE SHOWN ON PAGE 4.

ALL DIMENSIONS ARE IN INCHES.

FIG. 2

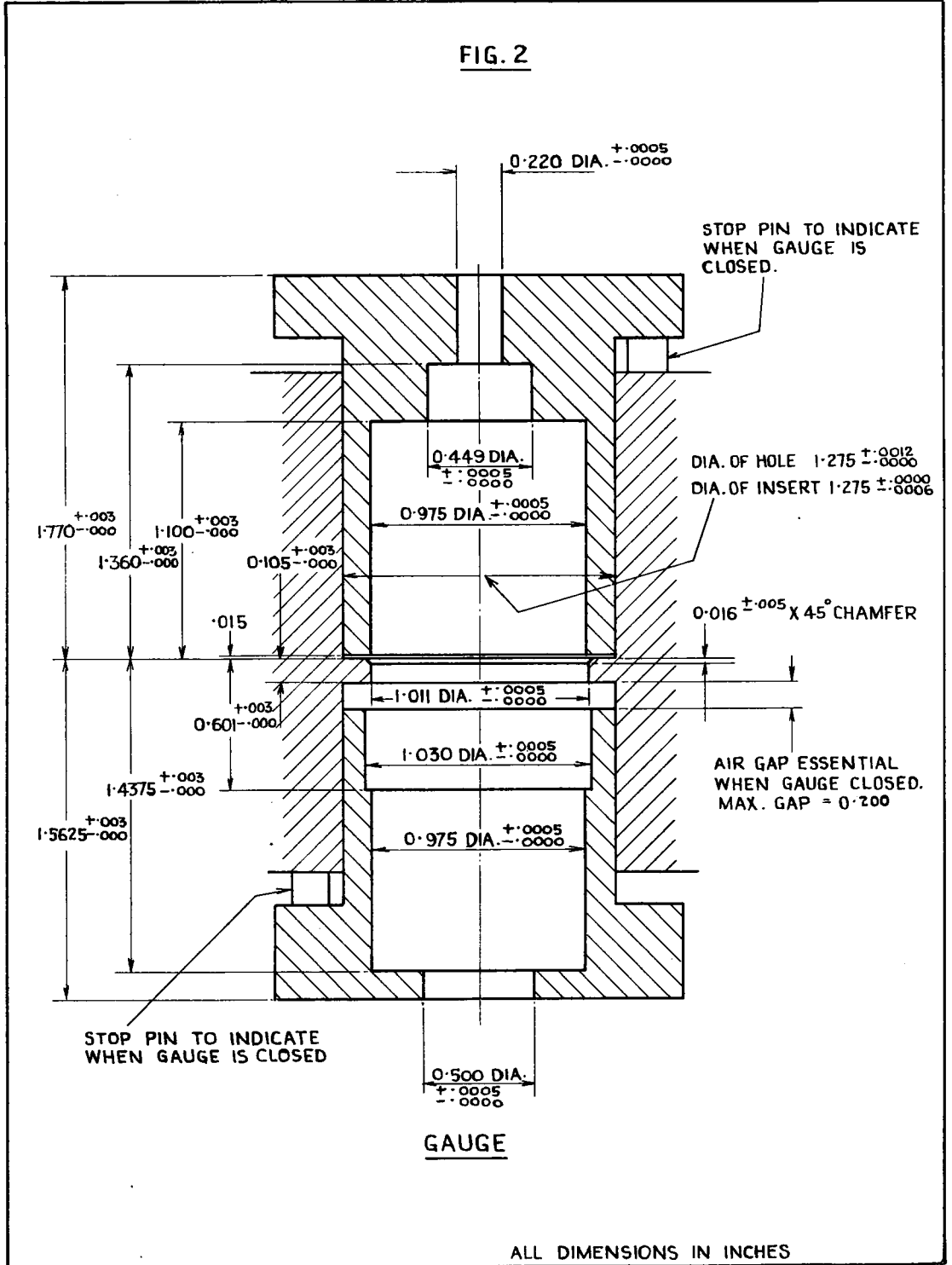

CV 2201|3/4

FIG 3.

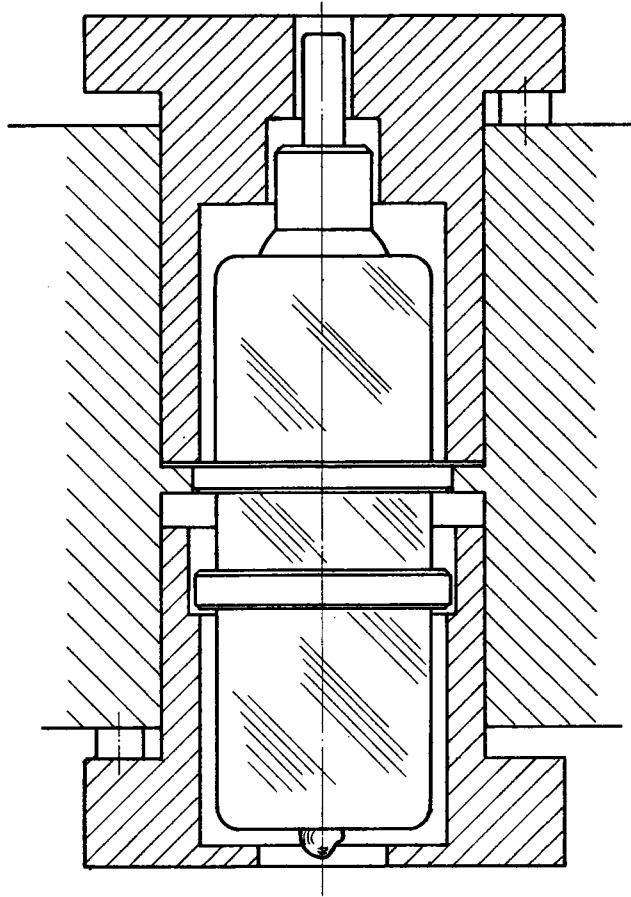

SHOWING VALVE IN
POSITION